

one

Mounting options
Product dimensions
Exploded drawing
Technical data



Mounting options: **with** wallbox
 Installation in drywall, stone or solid wall etc.

Attach one to the wallbox.

Power supply: 100-240Vac or PoE (Power over Ethernet)

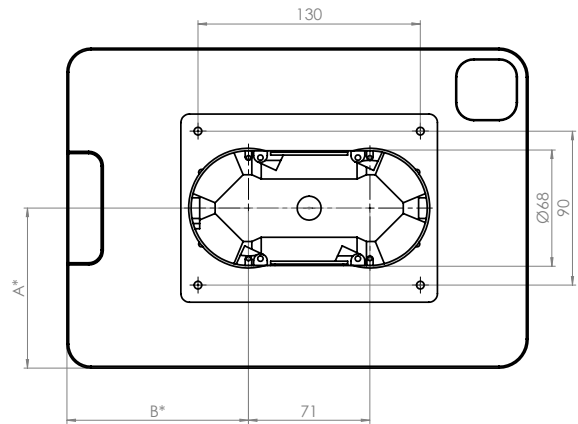
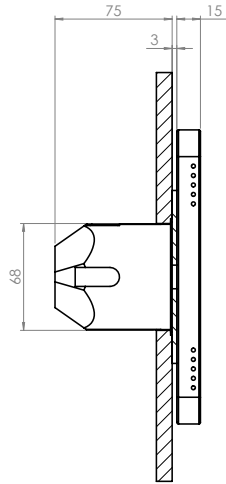

side view
 from left to right: wallbox, wall, wall spacer, one

back view
! Attention: Measurements show one for iPad 9.7 inch. Measurements for other generation on following page.

The size of one varies depending on the iPad generation. Mounting plate is always the same, it allows you to change iPad generation easily.

Scaled-ready drilling template at www.viveroo.com/downloads

Article:
 MountingSet Inwall
 Incl. wallbox, power supply unit and mounting material

Mounting options: **without** wallbox
 Installation in furniture, cabinets, wooden materials displays etc.

Direct screw-mounting.

Power supply unit:
 USB-connector or PoE (Power over Ethernet)

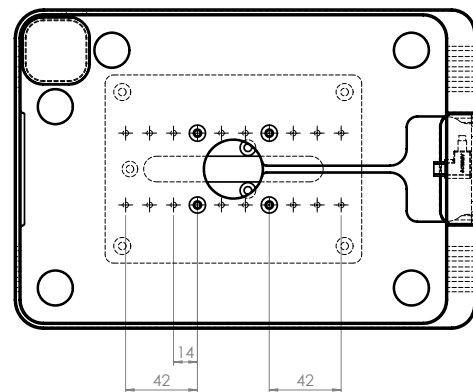

back view
! Attention: Measurements show one for iPad 9.7 inch. Measurements for other generation on following page.

The size of one varies depending on the iPad generation. Mounting plate is always the same, it allows you to change iPad generation easily.

Scaled-ready drilling template at www.viveroo.com/downloads

Article:
 MountingSet Furniture
 Incl. wallbox, power supply unit and mounting material

one für ...

... iPad mini 6

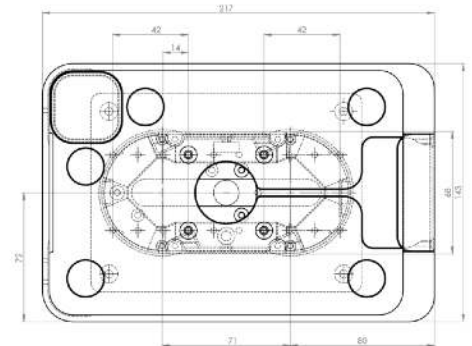

... iPad 10.2 inch, Air (2019),
Pro 10.5 inch

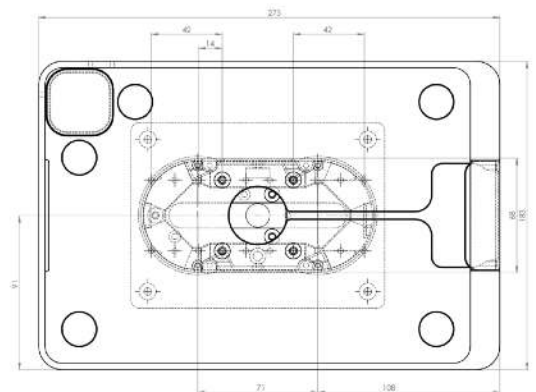

... iPad Pro 11 inch, Air 10.9 inch

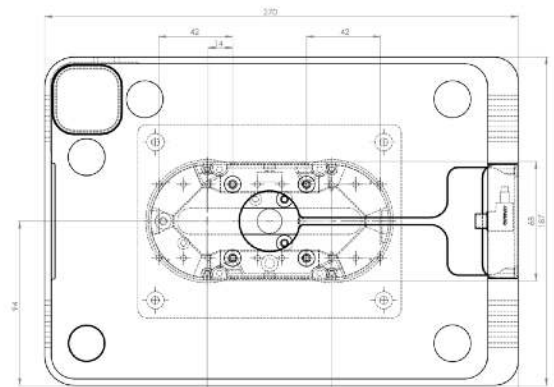

... iPad Pro 12.9 inch

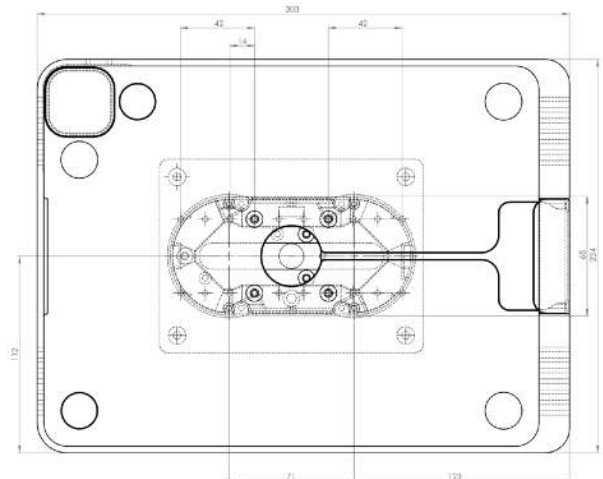

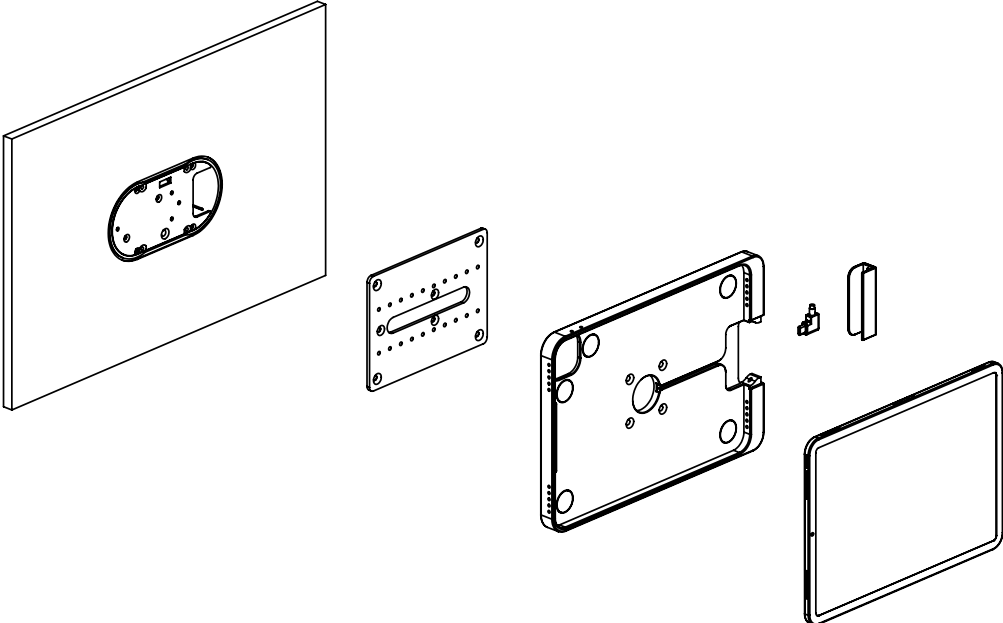

one

Product contents	<ul style="list-style-type: none"> - User manual one - one <p>Please note! External cable, power supply and mounting screws are included in MountingSet.</p>
Compatibility	Electrical operation of viveroo products is permitted only in connection with viveroo MountingSet and power supply and cable included in the MountingSet. Operation of viveroo iPad mounts without a MountingSet will lead to immediate loss of guarantee and warranty.
Weight	<ul style="list-style-type: none"> for iPad mini: 740 g for iPad 10.2 inch (09/2019), Air (2019), Pro 10.5 inch: 866 g for iPad Pro 11 inch, Air 10.9 inch: 952 g for iPad Pro 12.9 inch: 1.118 g
Electrical connections	5,4Vdc 3A via USB-A
Disconnect from power supply	viveroo iPad mounts may be removed from the power supply via the circuit breaker in the respective rooms.
CE & Co.	All viveroo products have CE certification. viveroo iPad mounts are quality "Made in Germany". We use only high-quality parts and components produced by market leaders. viveroo customers are proud of their iPad garage.
one with PoE Adapter	<ul style="list-style-type: none"> Input 48-56Vdc via RJ45 port PoE standard 802.3af for iPads with Lightning connector; 802.3at for iPads with USBC connector

Mounting Furniture

Product contents	<ul style="list-style-type: none"> - Installation guide Furniture - USB Power Adapter (For USB-A: 100-240Vac, 50/60Hz, 12,5W, For USB-C: 100-240Vac, 50/60Hz, PD 3.0, up to 18W) - True-to-scale drilling template - Mounting material
-------------------------	--

Mounting Inwall

Product contents	<ul style="list-style-type: none"> - Installation guide Inwall - free flush-mount box with installation disc, incl. integrated level - Power supply unit (IN: 100-240 Vac, 50/60 Hz, OUT: 5,2 Vdc) installed on installation plate or USB Power Adapter USB-C: 100-240Vac, 50/60Hz, PD 3.0, up to 18W
-------------------------	--

Technical changes and mistakes are excepted.